

MANUFACTURED HOME/MOBILE HOME SET UP SPECIFICATIONS

TIE DOWNS

Tie downs are required on all manufactured homes. Approvals as per:

- A. Manufactures specifications, OR
- B. Building Department approval as per ANSI A225.1 - 1994, OR
- C. Licensed Engineer or Architect approval

BLOCKING

Blocking shall be installed according to manufacturer's requirements. Please have specifications available for verification at the time of inspection. Blocking & tie down inspection must be completed before occupancy.

STRIP FOOTINGS

- A. Install as per manufacturer's specifications
- B. Rebar **must not** be in contact with soil
- C. Rebar must be tied and secured in place for inspection

MINIMUM COUNTY STANDARDS

Starting a maximum of 2' from the end of a rail, piers shall not exceed 8' on center (O.C.) NOTE: 8"x8"x16" blocks shall have cells vertical and plumb. Black plastic ground cover (6 mil) is required.

A pier may be made of a double stack of 8"x8"x16" blocks if the blocks are not stacked more than 5 blocks high. Each row of blocks in such a pier shall be stacked at right angles to the abutting rows of blocks. The pier shall be capped with up to two 2"x 8"x 16" wood or concrete blocks. The pier shall be installed so that the joint between the cap blocks is at right angles to the main frame longitudinal member.

A pier may be made with more than 5 rows of blocks if the stacked blocks are filled with 2000 psi concrete or mortar. A licensed architect or professional engineer must approve a foundation system that includes a pier that is higher than 72" (9 blocks) high, or in which more than 20 % of the piers exceed 40" (5 Blocks) high.

SEE DIAGRAM #1 ON REVERSE SIDE.

PLUMBING

WASTE: ABS pipe shall be supported every 4' O.C. max.

Clean-outs shall be provided at uppermost end and at branches greater than 5' in length.

Water: Water supply 3/4" min C-PVC shall have building shut-off and drain.

External hose bibs shall have back-syphon device.

SKIRTING

Skirting shall be of material that is resistant to decay.

Vents: Underfloor ventilation to equal 1 sq. ft. per 150 sq. ft. of underfloor area.(Example: 14'x57' home needs six (6), 8"x16" vents). Vents are to be non-closable, screened and equally spaced and as high as possible.

Smooth bore dryer vent duct to be vented to the exterior.

Access: Provide one 18"x 24" min. underfloor access per transportable section (recommend one near water inlet).

EXIT STAIRWAYS

Provide a 36"x36" min. landing at each exterior doorway. Landing shall not be more than 7 3/4 " below the threshold of the doorway.

Stairs: Stairway is to be min. 36" in width, steps shall have 7 3/4 " max. rise (up) and 10" min. run (tread). If covered, it must have 6'8" min. headroom measured from the plain of the nosing of the treads.

Handrail: For 4 or more risers, provide a 34" to 38" high handrail. Handgrip portion to be continuous material 1 1/4" to 2" in cross section with ends (both top and bottom) returned or end in a safety post.

Guardrail: For levels that are 30" or greater above ground, provide a 36" min. height guardrail. Intermediate rails and or pattern shall be spaced such that a 4" diameter ball can not pass through.

MINIMUM PIER FOUNDATION FOR SETTING A MOBILE HOME

DIAGRAM #1

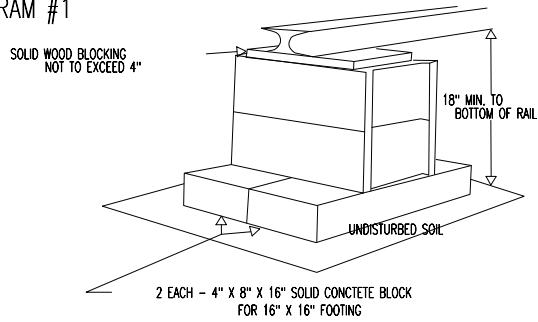

- 6 MIL. BLACK PLASTIC GROUND COVER REQUIRED
- POURED FOOTING SHALL BE A MINIMUM OF 6" DEEP AND 16" WIDE WITH 2 STICKS OF #4 REBAR
- FORMS TO BE INSPECTED BEFORE POURING CONCRETE
- ROUND PIER FOUNDATION MINIMUM DIAMETER 18" SQUARE
- POURED SQUARE PIER FOUNDATION MINIMUM DIAMETER 18" SQUARE
- ALL FOUNDATIONS TO SIT ON UNDISTURBED SOIL, AND ALL DEBRIS SHALL BE REMOVED FROM BENEATH MOBILE HOME

EXIT STAIRWAY

DIAGRAM #2

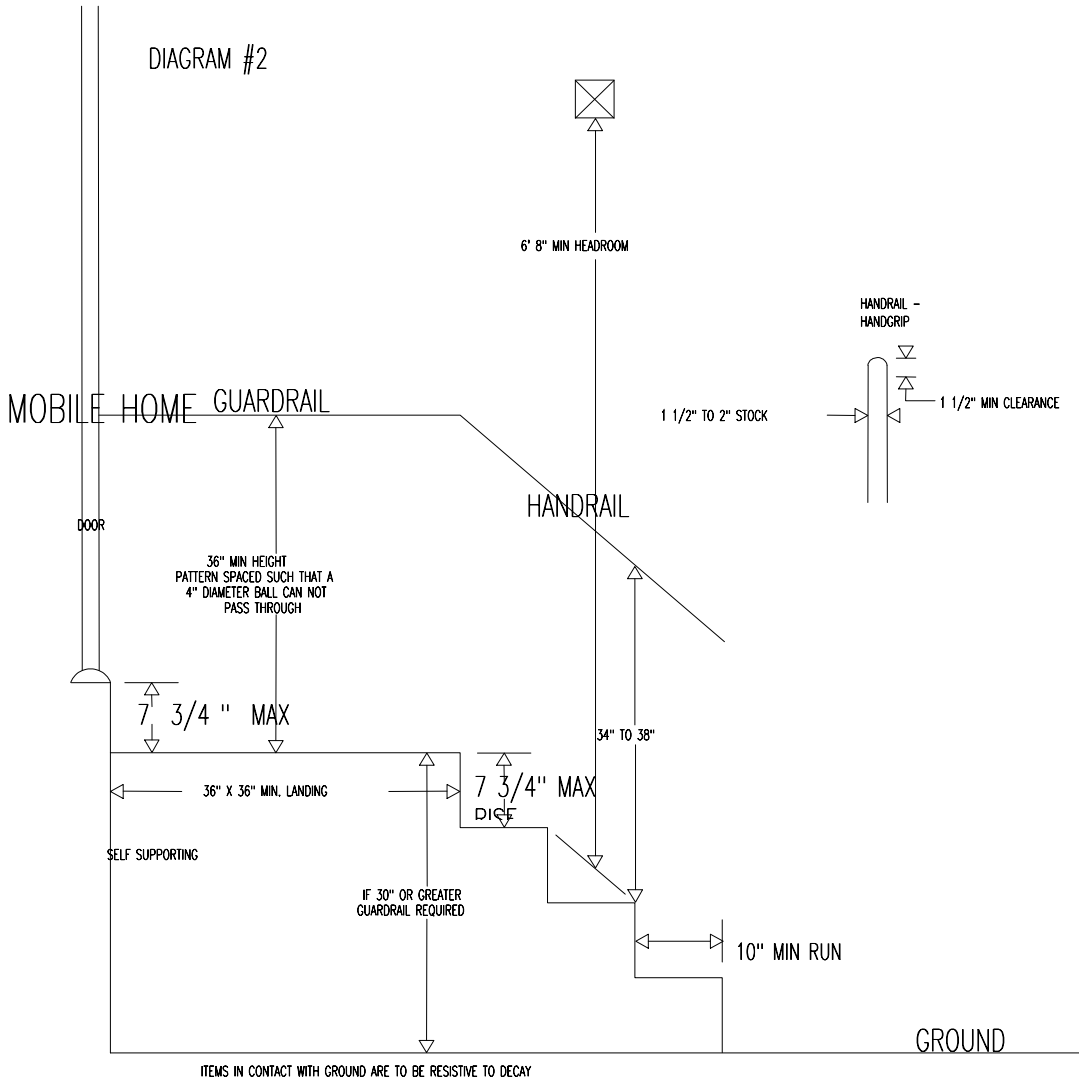

ALL LANDINGS, STAIRS, AND ADDITIONS MUST BE SELF SUPPORTING

